

Cameron Park Community Services District
2502 Country Club Drive
Cameron Park, CA 95682



Fire and Emergency Services Committee
Tuesday, September 1, 2020
5:30 p.m.

TELECONFERENCE ZOOM MEETING
<https://us02web.zoom.us/j/86299673524>

Meeting ID: 862 9967 3524

(Teleconference/Electronic Meeting Protocols are attached)

Agenda

Members: Chair Director Ellie Wooten (EW), Vice Chair Director Monique Scobey (MS)
Alternate Director Eric Aiston (EA)

Staff: General Manager Jill Ritzman, Chief Sherry Moranz, Chief Jed Gaines

CALL TO ORDER

ROLL CALL

Public testimony will be received on each agenda item as it is called. Principal party on each side of an issue is allocated 10 minutes to speak, individual comments are limited to 3 minutes except with the consent of the Committee; individuals shall be allowed to speak on an item only once. Members of the audience are asked to volunteer their name before addressing the Committee. The Committee reserves the right to waive said rules by a majority vote.

ADOPTION OF AGENDA

APPROVAL OF CONFORMED AGENDA

OPEN FORUM

Members of the public may speak on any item not on the agenda that falls within the responsibilities of the Committee.

DEPARTMENT MATTERS

- 1. Categorical Exemption for Fire Fuel Reduction (J. Ritzman)**
- 2. Volunteer Fire Assistance Grant (J. Gaines)**

3. Staff Updates

- a. Fire Department Reports (K. Richards, J. Gaines)
- b. Fire Training Tower (S. Moranz)

4. Items for October and Future Committee Agendas

- Grand Jury Response Update

5. Items to take to the Board of Directors

MATTERS TO AND FROM COMMITTEE MEMBERS

ADJOURNMENT



Teleconference/Electronic Meeting Protocols

Cameron Park Community Services District

(Effective April 2, 2020)

WHEREAS, on March 4, 2020, Governor Newsome proclaimed a State of Emergency to exist in California as a result of the threat of COVID-19; and

WHEREAS, March 17, 2020, Governor Newsome issued Executive Order N-29-20 suspending parts of the Brown Act that required in-person attendance of Board members and citizens at public meetings; and

WHEREAS, on March 19, 2020, Governor Newsome issued Executive Order N-33-20 directing most individuals to shelter at home or at their place of residence.

NOW, THEREFORE, the Cameron Park Community Services District will implement the following protocols for its Board and committee meetings.

The guidance below provides useful information for accessing Cameron Park Community Services District (“District”) meetings remotely and establishing protocols for productive meetings.

BOARD AND COMMITTEE MEMBERS:

- **Attendance.** Board and Committee Members should attend District meetings remotely from their homes, offices, or an alternative off-site location. As per the Governor’s updated Executive Order N-29-20, there is no longer a requirement to post agendas at or identify the address of these locations.
- **Agendas.** Agenda packages will be made available on the District’s website. They will also be sent by email to all Board and Committee Members. Note that under the circumstances, District staff may not be able to send paper packets.
- **Board and Committee Member Participation.** Meeting Chair(s) will recognize individual Board and Committee Members and unmute their device so that comments may be heard or will read comments if they are provided in writing only.

PUBLIC PARTICIPATION:

- **Attendance.** The District’s office will remain closed to the public until further notice. Members of the public will be able to hear and/or see public meetings via phone, computer, or smart device. Information about how to observe the meeting is listed on the agenda of each meeting.
- **Agendas.** Agendas will be made available on the District’s website and to any members of the public who have a standing request, as provided for in the Brown Act.
- **Public Participation.** The public can observe and participate in a meeting as follows:
 - **How to Observe the Meeting:**
 - **Telephone:** Listen to the meeting live by calling Zoom at (669) 900-6833 or (346) 248 7799. Enter the Meeting ID# listed at the top of the applicable Board or Committee agenda followed by the pound (#) key. More phone numbers can be found on Zoom’s website at <https://us04web.zoom.us/j/91011220960> if the line is busy.
 - **Computer:** Watch the live streaming of the meeting from a computer by navigating to the link listed at the top of the applicable Board or Committee agenda using a computer with internet access that meets Zoom’s system requirements (<https://support.zoom.us/hc/en-us/articles/201362023-System-Requirements-for-PC-Mac-and-Linux>)
 - **Mobile:** Log in through the Zoom mobile app on a smartphone and enter the Meeting ID# listed at the top of the applicable Board or Committee agenda.
 - **How to Submit Public Comments:**
 - **Before the Meeting:** Please email your comments to admin@cameronpark.org, with “Public Comment” in the subject line. In the body of the email, include the agenda item number and title, as well as your comments. If you would like your comment to be read aloud at the meeting (not to exceed 3 minutes at staff’s cadence), prominently write “Read Aloud at Meeting” at the top of the email. Emails running longer than the time limit will not be finished. All comments received at least 2 hours prior to the meeting on the day the meeting will be held, will be included as an agenda supplement on the District’s website

under the relevant meeting date, and provided to the Directors/Committee Members at the meeting. Comments received after that time will be treated as contemporaneous comments.

- **Contemporaneous Comments:** During the meeting, the Board President/Committee Chair or designee will announce the opportunity to make public comments. If you would like to make a comment during this time, you may do so by clicking the “raise hand” button. You will be addressed and un-muted when it is your turn to speak (not to exceed the 3 minute public comment time limit).

FOR ALL PARTICIPANTS:

- **Get Connected:** Please download Zoom application for your device and familiarize yourself with how to utilize this tool. There is no cost for using the application.
- **Ensure Quiet.** All audience members will be muted during the meeting until they are addressed by the Board/Committee as their time to speak. Please make every effort to find a location with limited ambient noise. Please turn off the ringer on your phone and other notification sounds on your devices to reduce interruptions.

We anticipate that this process of moving to remote meetings will likely include some challenges. Please bear with us as we navigate this process.

Cameron Park Community Services District
2502 Country Club Drive
Cameron Park, CA 95682



Fire and Emergency Services Committee
Tuesday, July 7, 2020
5:30 p.m.

TELECONFERENCE ZOOM MEETING
<https://us02web.zoom.us/j/82665784934>

Meeting ID: 826 6578 4934

(Teleconference/Electronic Meeting Protocols are attached)

Conformed Agenda

Members: Chair Director Ellie Wooten (EW), Vice Chair Director Monique Scobey (MS)
Alternate Director Eric Aiston (EA)

Staff: General Manager Jill Ritzman, Chief Sherry Moranz, Chief Jed Gaines

CALL TO ORDER – 5:33pm

ROLL CALL – MS/EA (EW was absent)

Public testimony will be received on each agenda item as it is called. Principal party on each side of an issue is allocated 10 minutes to speak, individual comments are limited to 3 minutes except with the consent of the Committee; individuals shall be allowed to speak on an item only once. Members of the audience are asked to volunteer their name before addressing the Committee. The Committee reserves the right to waive said rules by a majority vote.

ADOPTION OF AGENDA – Approved

APPROVAL OF CONFORMED AGENDA - Approved

OPEN FORUM

Members of the public may speak on any item not on the agenda that falls within the responsibilities of the Committee.

DEPARTMENT MATTERS

1. El Dorado County Grand Jury 19-06 West Slope Protection Update (J. Ritzman)

- *Reviewed and discussed El Dorado County Grand Jury 19-06 West Slope Protection Update. Add "Response to Recommendations - 3. Recommendation requires further analysis or study noting a timeframe not to exceed six months from date Grand Jury Report was issued". Move to the Board with support.*

2. Staff Updates

- a. Fire Department Report (J. Gaines)
- b. Cameron Park Lake Dam EAP Update (J. Ritzman)

3. Items for August and Future Committee Agendas

- *Fire Training Tower*
- *Grand Jury Response Update*

4. Items to take to the Board of Directors

- *El Dorado County Grand Jury 19-06 West Slope Protection Update*

MATTERS TO AND FROM COMMITTEE MEMBERS

ADJOURNMENT – 6:29pm



Agenda Transmittal

DATE: September 1, 2020

FROM: Jill Ritzman, General Manager

AGENDA ITEM #1: CATEGORICAL EXEMPTION, CAMERON PARK HAZARDOUS FUEL REDUCTION PROJECT

RECOMMENDED ACTION: REVIEW AND FORWARD TO THE BOARD OF DIRECTORS

Background

The State of California requires compliance with California Environmental Quality Act (CEQA) and its guidelines for discretionary projects being performed by a public agency. While the Hazardous Fuel Reduction Project, funded by the California Climate Investment (CCI) grant, is extremely important to protect residents in Cameron Park, it is considered a discretionary project. Staff deemed it best to seek environmental review of the proposed project.

Cameron Park Community Services District (District) is considered the lead agency for approval of the environmental document, because the CCI grant was awarded to the District and much of the project will be held on District properties.

Discussion

The District contracted with the El Dorado Resource Conservation District (RCD) to conduct the review consistent with CEQA guidelines, to be funded by the CCI grant. RCD concluded that the Hazardous Fuel Reduction Project is exempt from CEQA; therefore, a Notice of Exemption is prepared for consideration by the Board of Directors.

The Notice of Exemption was prepared because the project involves *minor alteration of vegetation, including fuel management activities to reduce the volume of flammable vegetation. The activities do not result in the taking of endangered, rare, or threatened plant or animal species or significant erosion and sedimentation of surface waters. According to the Department of Fish*

and Game's Natural Diversity Database, listed plants or animal species affected by the project will be protected through avoidance.

RCD determined that there will be no impact to historic or cultural resources due to lack of ground disturbance. As required by CEQA, staff sent letters to four tribes considered to be stakeholders: Auburn Rancheria, Shingle Springs Miwok, Washoe Tribe, and Wilton Rancheria. The tribes have until September 6, 2020 to respond to the Notice of Exemption.

Once the Board of Directors approves the Notice of Exemption, the document will be sent to the County Board of Supervisors for approval.

Attachment:

1A – Notice of Exemption

NOTICE OF EXEMPTION

PROJECT TITLE	Cameron Park Hazardous Fuel Reduction		
PROJECT LOCATION	Clarksville and Shingle Springs USGS 7.5-minute Quadrangles, MDBM Township 10 North, Range 9 East, Sections 21, 28, 29 and 33 Township 9 North, Range 9 East, Sections 3, 4 and 5 It is approximately 28 miles east of Sacramento via Highway 50. See attached map.	COUNTY	El Dorado
LEAD AGENCY	Cameron Park Community Services District		
CONTACT	Jill Ritzman	PHONE	530-350-4651
ADDRESS	2502 Country Club Drive. Cameron Park, CA 95682		

PROJECT DESCRIPTION: The Cameron Park Community Services District (District) received funding from the State of California Department of Forestry and Fire protection (CAL FIRE) - Fire Prevention Grant Program (Agreement #5GG18101) to implement activities to reduce fire hazard and fuel loads on seven sites including 10 Assessors Parcels (see Attachment 1). These parcels are public open space or parkland and altogether total 107 +/- acres. Excluding lake surface area and parkland, the area proposed for treatment equate to 52 +/- acres.

Treatment prescriptions are determined for a given stand or unit based on site characteristics, proximity to residences and infrastructure, slope, and the presence of sensitive resources. Treatments include hand crews using hand tools to reduce vegetative cover. Material will be chipped on-site. The project would incorporate design features to avoid or minimize impacts to cultural sites, sensitive plant and wildlife species, and special habitats, such as wetlands or riparian areas. Such design features may include avoidance and specially designed treatments. Best management practices would be implemented to avoid air quality impacts from smoke, dust, and fumes, impacts of noise on sensitive receptors, and impacts to water quality and hydrology.

EXEMPTION STATUS

- Categorical Exemption Type/Section: Class 4; §15304 Minor Alterations to Land
- Statutory Exemption (state code section):
- Ministerial (§21080(b)(1); 15268)
- Declared Emergency (§21080(b)(3); 15269(a))
- Emergency Project (§21080(b)(4); 15269(b)(c))

REASONS PROJECT IS EXEMPT

Project involves minor alteration of vegetation, including fuel management activities to reduce the volume of flammable vegetation. The activities do not result in the taking of endangered, rare, or threatened plant or animal species or significant erosion and sedimentation of surface waters. According to the Department of Fish and game's Natural Diversity Database, listed plants or animal species affected by the project will be protected through avoidance. There will be no impact to historic or cultural resources due to lack of ground disturbance.

DATE RECEIVED FOR FILING

Jill Ritzman, General Manager Date



Agenda Transmittal

DATE: September 1, 2020

FROM: Sherry Moranz, Fire Chief

AGENDA ITEM #2: VOLUNTEER FIRE ASSISTANCE GRANT

RECOMMENDED ACTION: REVIEW AND FORWARD TO THE BOARD OF DIRECTORS

Introduction

The Cameron Park Community Services District Fire Department applied for Volunteer Fire Assistance federal grant funds to fund up to 50% of the cost of new radios. Total project costs were \$45,330 for 14 radios and ancillary equipment. Grant funds were requested to provide up-to-date mobile and portable communications to Fire Department staff. The current radios date back to 2007, which poses challenges due to the antiquated technology. New radios will be both NFPA and P25 compliance. Current radio technology is critical when responding to emergencies and communicating with other responding jurisdictions.

Discussion

The District was notified on August 10, 2020 that the grant application was approved for \$18,989. To receive funds, the District Board of Directors must approve a Resolution that accepts the funds and authorizes the General Manager to execute the grant Agreement. The expenditures and revenues will be included in the mid-year budget adjustment.

Attachments:

2A – Draft Resolution

2B – Grant Agreement

BEFORE THE BOARD OF DIRECTORS OF THE CAMERON PARK COMMUNITY SERVICES DISTRICT COUNTY OF EL DORADO, STATE OF CALIFORNIA

IN THE MATTER OF:

Resolution Number: 2020-xx

Approving the Department of Forestry and Fire Protection Agreement #7FG20014 for services from the date of last signatory on page 1 of the Agreement to June 30, 2021 under the Volunteer Fire Assistance Program of the Cooperative Forestry Assistance Act of 1978.

BE IT RESOLVED by the Board of Directors of the Cameron Park Community Services District that said Board does hereby approve the Agreement with the California Department of Forestry and Fire Protection dated as of the last signatory date on page 1 of the Agreement, and any amendments thereto. This Agreement provides for an award, during the term of this Agreement, under the Volunteer Fire Assistance Program of the Cooperative Fire Assistance Act of 1978 during the State Fiscal Year 2020-21 up to and no more than the amount of \$18,989.

BE IT FURTHER RESOLVED that the General Manager of said Cameron Park Community Services District be and hereby is authorized to sign and execute said Agreement and any amendments on behalf of the Cameron Park Community Services District.

The foregoing resolution was duly passed and adopted by the Board of Directors of the Cameron Park Community Services District, at a regular meeting thereof, held on the ___ day of _____, by the following vote:

AYES:

Signature, Board of Directors Member

NAYS:

Printed Name and Title
Monique Scobey, President

Signature, Board of Directors Member

Printed Name and Title
Eric Aiston, Vice President

-----CERTIFICATION OF RESOLUTION-----

ATTEST:

I, Jill Ritzman, Clerk of the Cameron Park Community Services District Board of Directors of Cameron Park Community Services District, California do hereby certify that this is a true and correct copy of the original Resolution # 2020-XX.

WITNESS MY HAND OR THE SEAL OF THE _____, on this _____ day of _____, _____.

OFFICIAL SEAL OR NOTARY CERTIFICATON

Signature

Title and Name of Local Agency

State of California
Dept. of Forestry and Fire Protection (CAL FIRE)
Cooperative Fire Programs
GRANT AGREEMENT

APPLICANT:**PROJECT TITLE:** Volunteer Fire Assistance Program**GRANT AGREEMENT:** 7FG20014**PROJECT PERFORMANCE PERIOD IS from Upon Approval through June 30, 2021.**

Under the terms and conditions of this Grant Agreement, the applicant agrees to complete the project as described in the project description, and the State of California, acting through the Dept. of Forestry & Fire Protection, agrees to fund the project up to the total state grant amount indicated.

PROJECT DESCRIPTION: Cost-share funds awarded to provide assistance to rural areas in upgrading their capability to organize, train, and equip local forces for fire protection.

Total State Grant not to exceed **\$18,989.48** (or project costs, whichever is less)

**The Special and General Provisions attached are made a part of and incorporated into this Grant Agreement.*

**STATE OF CALIFORNIA
DEPARTMENT OF FORESTRY
AND FIRE PROTECTION**

Applicant	
By _____	By _____
Signature of Authorized Representative	Title: Gabrielle Avina Staff Chief, Cooperative Fire Programs
Title _____	Date _____
Date _____	

CERTIFICATION OF FUNDING

AMOUNT OF ESTIMATE FUNDING \$18,989.48	GRANT AGREEMENT NUMBER 7FG20014	PO ID		
ADJ. INCREASING ENCUMBRANCE \$ 0.00	SUPPLIER ID			
ADJ. DECREASING ENCUMBRANCE \$ 0.00	PROJECT ID 354020DG2012133	ACTIVITY ID SUBGNT		
UNENCUMBERED BALANCE \$18,989.48	GL UNIT 3540	BUD REF 001	CHAPTER 6/7	FUND 0001
				ENY 2020
REPORTING STRUCTURE 35409206	SERVICE LOC 92698	ACCOUNT 5340580		ALT ACC 5340580002

I hereby certify upon my personal knowledge that budgeted funds are available for this encumbrance.

SIGNATURE OF CAL FIRE ACCOUNTING OFFICER _____

DATE _____

**VOLUNTEER FIRE ASSISTANCE PROGRAM
TERMS AND CONDITIONS**

DEPARTMENT OF FORESTRY AND FIRE PROTECTION

STATE OF CALIFORNIA
Natural Resources Agency

Agreement for the Volunteer Fire Assistance Program of the
Cooperative Forestry Assistance Act of 1978

THIS AGREEMENT, made and entered into **ON THE LAST SIGNATORY DATE ON PAGE 1**, by and between the STATE of California, acting through the Director of the Department of Forestry and Fire Protection hereinafter called "STATE", and _____

_____ hereinafter called "LOCAL AGENCY", covenants as follows:

RECITALS:

1. STATE has been approved as an agent of the United States Department of Agriculture, (USDA), Forest Service for the purpose of administering the Cooperative Forestry Assistance Act (CFAA) of 1978 (PL 95-313, United States Code, Title 16, Chapter 41, Section 2010 et seq., Volunteer Fire Assistance Program), hereinafter referred to as "VFA", and
2. The VFA has made funds available to STATE for redistribution, under certain terms and conditions, to LOCAL AGENCY to assist LOCAL AGENCY to upgrade its fire protection capability, and
3. LOCAL AGENCY desires to participate in said VFA.

NOW THEREFORE, it is mutually agreed between the parties as follows:

4. **APPROVAL: This Agreement is of no force or effect until signed by both parties and approved by the Department of General Services, if required. LOCAL AGENCY may not commence performance until such approval has been obtained.**
5. **TIMELINESS: Time is of the essence in this Agreement.**
6. **FORFEITURE OF AWARD: LOCAL AGENCY must return this Agreement and required resolution properly signed and executed to STATE at the address specified in paragraph 11, with a postmark no later than December 1, 2020 or LOCAL AGENCY will forfeit the funds.**
7. **GRANT AND BUDGET CONTINGENCY CLAUSE: It is mutually understood between the parties that this Agreement may have been written for the mutual benefit of both parties before ascertaining the availability of congressional appropriation of funds, to avoid program and fiscal delays that would occur if the Agreement were executed after that determination was made.**

This **Agreement** is valid and enforceable only if sufficient funds are made available to the STATE by the United States Government for the State Fiscal Year 2020 for the purpose of this program. In addition, this **Agreement** is subject to any additional restrictions, limitations, or conditions enacted by the Congress or to any statute enacted by the Congress that may affect the provisions, terms, or funding of this **Agreement** in any manner.

The parties mutually agree that if the Congress does not appropriate sufficient funds for the program, this **Agreement** shall be amended to reflect any reduction in funds.

The STATE has the option to invalidate the **Agreement** under the 30-day cancellation clause or to amend the **Agreement** to reflect any reduction in funds.

8. **REIMBURSEMENT:** STATE will reimburse LOCAL AGENCY, from funds made available to STATE by the Federal Government, an amount not to exceed **\$18,989.48** on a 50/50 matching funds basis, for the performance of specific projects and/or purchase of specific items identified in Proposed Project, Application for Funding, attached hereto. **Reimbursement will be only for those projects accomplished and/or items purchased between THE LAST SIGNATORY DATE ON PAGE 1 and JUNE 30, 2021.** This sum is the sole and maximum payment that STATE will make pursuant to this Agreement. **LOCAL AGENCY must bill STATE at the address specified in paragraph 11, with a postmark no later than September 1, 2021 in order to receive the funds.** The bill submitted by LOCAL AGENCY must clearly delineate the projects performed and/or items purchased. A vendor's invoice and proof of payment to vendor(s) must be included for items purchased.
9. **LIMITATIONS:** Expenditure of the funds distributed by STATE herein is subject to the same limitations as placed by the VFA, upon expenditure of United States Government Funds. Pursuant to Title 7 of the Code of Federal Regulations, Section 3016.32 subject to the obligations and conditions set forth in that section; title to any equipment and supplies acquired under this **Agreement** vests with the LOCAL AGENCY. For any equipment items over \$5,000, the federal government may retain a vested interest in accordance with paragraph 16 below.
10. **MATCHING FUNDS:** Any and all funds paid to LOCAL AGENCY under the terms of this **Agreement**, hereinafter referred to as "VFA Funds", shall be matched by LOCAL AGENCY on a dollar-for-dollar basis, for each project listed on attachment(s) hereto identified as "Proposed Project". No amount of unpaid "contributed" or "volunteer" labor or services shall be used or consigned in calculating the matching amount "actually spent" by LOCAL AGENCY.
LOCAL AGENCY shall not use VFA Funds as matching funds for other federal grants, including Department of Interior (USDI) Rural Fire Assistance grants, nor use funds from other federal grants, including USDI Rural Fire Assistance grants, as matching funds for VFA Funds.

11. ADDRESSES: The mailing addresses of the parties hereto, for all notices, billings, payments, repayments, or any other activity under the terms of the Agreement, are:

LOCAL AGENCY: _____

Attention: _____
Telephone Number(s): _____
FAX Number: _____
E-mail _____

**STATE: Department of Forestry and Fire Protection
Grants Management Unit, Attn: Megan Esfandiary
P. O. Box 944246
Sacramento, California 94244-2460
PHONE: (916) 894-9845**

12. PURPOSE: Any project to be funded hereunder must be intended to specifically assist LOCAL AGENCY to organize, train, and/or equip local firefighting forces in the aforementioned rural area and community to prevent or suppress fires which threaten life, resources, and/or improvements within the area of operation of LOCAL AGENCY.
13. COMBINING: In the event funds are paid for two or more separate, but closely related projects, the 50/50 cost-sharing formula will be applied to the total cost of such combined projects.
14. OVERRUNS: In the event that the total cost of a funded project exceeds the estimate of costs upon which this Agreement is made, LOCAL AGENCY may request additional funds to cover the **Agreement** share of the amount exceeded. However, there is no assurance that any such funds are, or may be, available for reimbursement. Any increase in funding will require an amendment.
15. UNDERRUNS: In the event that the total cost of a funded project is less than the estimate of costs upon which this **Agreement** is made, LOCAL AGENCY may request that additional eligible projects/items be approved by STATE for **Agreement** funding. However, there is no assurance that any such approval will be funded. Approval of additional projects/items, not listed on the Proposed Project application, made by STATE, will be in writing and will require an amendment.
16. FEDERAL INTEREST IN EQUIPMENT: The Federal Government has a vested interest in any item purchased with VFA funding in excess of \$5,000 regardless of the length of this **Agreement**, until such time as the fair market value is less than \$5,000. The VFA percentage used to purchase the equipment will be applied to the sale price and recovered for the Government during the sale. This percentage will remain the same even following depreciation. The Federal Government may not have to be reimbursed if the disposal sale amounts to a fair market value of less than \$5,000. LOCAL AGENCY will notify STATE of the disposal of such items.

17. EQUIPMENT INVENTORY: Any single item purchased in excess of \$5,000 will be assigned a VFA Property Number by the STATE. LOCAL AGENCY shall forward a copy of the purchase documents listing the item, brand, model, serial number, any LOCAL AGENCY property number assigned, and a LOCAL AGENCY contact and return address to STATE at the address specified in paragraph 11. The STATE will advise the LOCAL AGENCY contact of the VFA Property Number assigned.
18. AUDIT: LOCAL AGENCY agrees that the STATE, the Department of General Services, the Bureau of State Audits, or their designated representative shall have the right to review and to copy any records and supporting documentation pertaining to the performance of this **Agreement**. LOCAL AGENCY agrees to maintain such records for possible audit for a minimum of three (3) years after final payment, unless a longer period of records retention is stipulated. LOCAL AGENCY agrees to allow the auditor(s) access to such records during normal business hours and to allow interviews of any employees who might reasonably have information related to such records. Further, LOCAL AGENCY agrees to include a similar right of the State of California to audit records and interview staff in any subcontract related to performance of this **Agreement**. (GC 8546.7, PCC 10115 et seq., CCR Title 2, Section 1896).
19. DISPUTES: In the event of any dispute over qualifying matching expenditures of LOCAL AGENCY, the dispute will be decided by STATE and its decision shall be final and binding.
20. INDEMNIFICATION: LOCAL AGENCY agrees to indemnify, defend, and save harmless, the STATE, its officers, agents, and employees, from any and all claims and losses, accruing or resulting to any and all contractors, subcontractors, suppliers, laborers, and any other person, firm or corporation furnishing or supplying work services, materials, or supplies in connection with the performance of this **Agreement**, and from any and all claims and losses accruing or resulting to any person, firm or corporation who may be injured or damaged by LOCAL AGENCY in the performance of this **Agreement**.
21. DRUG-FREE WORKPLACE REQUIREMENTS: LOCAL AGENCY will comply with the requirements of the Drug-Free Workplace Act of 1990 and will provide a drug-free workplace by taking the following actions:
 - a. Publish a statement notifying employees that unlawful manufacture, distribution, dispensation, possession or use of a controlled substance is prohibited and specifying actions to be taken against employees for violations.
 - b. Establish a Drug-Free Awareness Program to inform employees about:
 - 1) the dangers of drug abuse in the workplace;
 - 2) the person's or organization's policy of maintaining a drug-free workplace;

- 3) any available counseling, rehabilitation and employee assistance programs; and,
- 4) penalties that may be imposed upon employees for drug abuse violations.

c. Every employee who works on the proposed **Agreement** will:

- 1) receive a copy of the company's drug-free workplace policy statement; and,
- 2) agree to abide by the terms of the company's statement as a condition of employment on the **Agreement**.

Failure to comply with these requirements may result in suspension of payments under the **Agreement** or termination of the **Agreement** or both and LOCAL AGENCY may be ineligible for funding of any future State **Agreement** if the department determines that any of the following has occurred: (1) the LOCAL AGENCY has made false certification, or violated the certification by failing to carry out the requirements as noted above. (GC 8350 et seq.)

22. **TERM:** The term of the Agreement SHALL COMMENCE ON THE LAST SIGNATORY DATE ON PAGE 1 and continue through June 30, 2021.
23. **TERMINATION:** This **Agreement** may be terminated by either party giving 30 days written notice to the other party or provisions herein amended upon mutual consent of the parties hereto.
24. **AMENDMENTS:** No amendment or variation of the terms of this **Agreement** shall be valid unless made in writing, signed by the parties and approved as required. No oral understanding or **Agreement** not incorporated in the **Agreement** is binding on any of the parties.
25. **INDEPENDENT CONTRACTOR:** LOCAL AGENCY, and the agents and employees of LOCAL AGENCY, in the performance of this **Agreement**, shall act in an independent capacity and not as officers or employees or agents of the STATE or the Federal Government.



Cameron Park
Community Services District



Agenda Transmittal

DATE: September 1, 2020

FROM: Kalan Richards, Battalion Chief

AGENDA ITEM #3A: FIRE DEPARTMENT REPORT

RECOMMENDED ACTION: RECEIVE AND FILE

1- Call Statistics

- August 2019 **186**
- August 2020 **238** (up 28%)
- YTD 2019 **2196**
- YTD 2020 **2065** (down 5%)

2- New E-88 Update

- Took delivery on July 30th
- On July 31st, evaluated performance (power, mechanical, pumping, electrical)
- Preliminary inspection on July 31st, with FEM Hogan, found about a dozen minor items needing repair
- Aug 13th meeting with Scott Beck to finalize repair list and specifications for mounting and outfitting
- Aug 22nd driver delivery to Rialto for factory/warranty repairs and adjustments, along with tool mounting and outfitting (estimated 4 weeks)
- Sept. 14th is our appointment with Gilly's for striping and decals

3- Assistance By Hire of CPFD Apparatus to CAL FIRE

- E-289, E389, E388, U88, U89 and U289 all rented out to CAL FIRE AEU to support Local, Regional and statewide wildfire response and preparation

4- LED lighting at station 89

- All lighting at station 89 is currently being converted over to cost efficient LEDs

Attachment:

August Fire Department Board Report



CAMERON PARK FIRE DEPARTMENT STAFF REPORT

To: Board of Directors
From: Jed Gaines, Battalion Chief
Regarding: Fire Department Report for August 19, 2020 - Board Meeting

Recommended Action: Receive and File

Incidents for the Month of July 2020

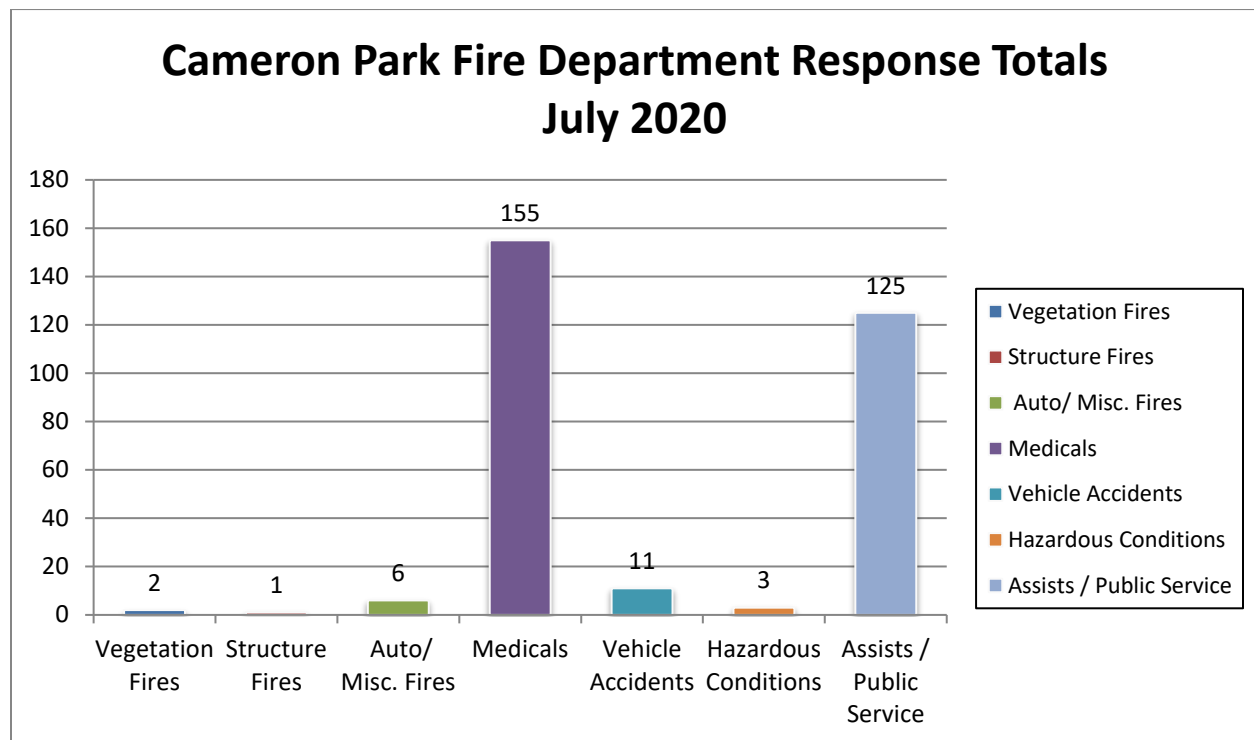

Incidents have increased by 11% for the month of July compared to July of 2019.

Total incidents have decreased by 8.5% for the calendar year of 2020 compared to 2019.



CAMERON PARK FIRE DEPARTMENT STAFF REPORT

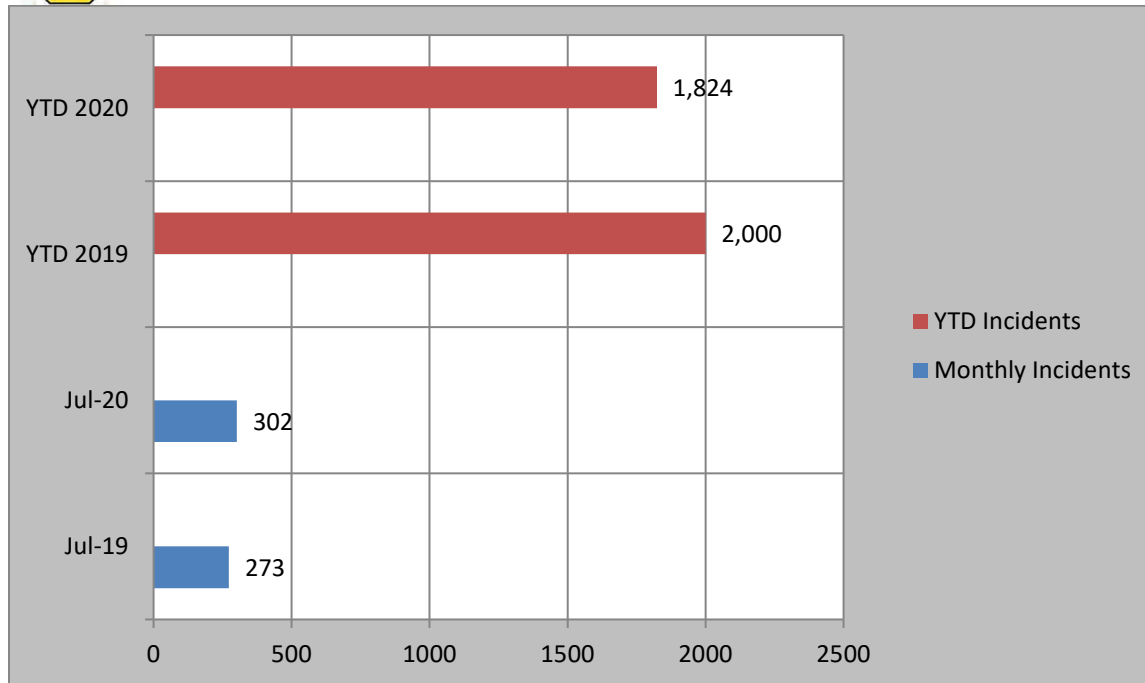

FIRE DEPARTMENT OPERATIONS AND ADMINISTRATION

Structure Fire on Fairway Drive.

Both Engine 388 and 389 were rented out for several weeks during the month of July.

Took delivery of our new fire engine 88. It is currently going through the mechanical inspection and will be sent out for compartment equipment build. We are hopeful that it will be in-service by September.

We have 5 employees that have been trained on administering a COVID test for local CAL FIRE employees only. This will help in expediting the results of first responders.

FIRE PREVENTION WEED ABATEMENT SUMMARY

8 reinspection's were completed on habitable structures in the District.

6 State mandated inspections were completed by the Fire Marshal.

CCI Grant reimbursement checks have started to come in for 2019-2020 fiscal year expenditures.

CONSTRUCTION CONTRACT

THIS AGREEMENT, made this 31st day of August, 2020, between **Cameron Park Community Services District** hereinafter Called, Owner, whose address is 2505 Country Club Drive, Cameron Park, CA 95682, and **Lamon Construction Co., Inc.**, 871 Von Geldern Way, Yuba City, CA 95991, hereinafter called Contractor. License No. 174828

In consideration of the covenants and agreements herein contained, the parties hereto agree as follows:

1. Contractor agrees to construct and complete in a good, workmanlike and substantial manner, upon the real property hereinafter described, furnishing all labor, materials, tools and equipment therefore, (hereinafter called the structure, whether one or more buildings or improvements), upon the following 3200 Country Club Drive, next to Fire Station 89, described real property.

2. The structure is to be constructed and completed in strict conformance with plans and specifications Provided by Fire Facilities Inc.

General Scope: Provide Foundation and Erect Fire Tower (Tower material provided by others) per attached quote, standard exclusions to the contract, parts list, and drawings. No demolition or site work is included.

Lien Holder is

(if no Lien Holder is named, all references to same is to be disregarded)

The structure is also to be constructed and completed in strict compliance with the laws, ordinances, rules and regulations of competent public authority, and owner is to apply for and obtain all required permits, paying all fees therefore, all other fees required by such public authority.

3. In consideration of the covenants and agreements herein being strictly performed and kept by Contractor, including the supplying of all labor, materials and services by this Contract, and the construction and completion of the structure, Owner agrees to pay the Contractor the sum of \$ **268,000**, in progress payments with **5%** retention held until substantial completion.

4. The Contractor agrees to commence work within **30 days** after receipt of written notice from the owner and Lien Holder so to do, to prosecute said work diligently and continuously to completion, and in any and all events to complete the same within **90 days** after commencement of work as aforesaid, subject to work or place any materials on the site thereof prior to receipt of such notice from the owner.

5. Contractor shall pay promptly all valid bills and charges for material, labor or otherwise in connection with or arising out of the construction of said structure and will hold Owner of the property free and harmless against all liens and claims of lien for labor and material, or either of them, filed against the property or any part thereof, and from all expense and liability in connection therewith, including, but not limited to, court costs and attorney's fees resulting or arising therefrom. Should any liens or claims of lien be filed for record against the property, or should Owner receive notice of any unpaid bill or charge in connection with the construction, Contractor shall forthwith either pay and discharge the same and cause the same to be released of record, or shall furnish Owner with proper indemnity either by satisfactory title policy, which indemnity shall also be subject to approval of Lien Holder.

6. Contractor shall, if requested, before being entitled to receive the second or any subsequent payment herewith, furnish to Owner all bills paid to that date, properly receipted and identified, covering work done upon and materials furnished for said structure and showing and expenditure of an amount not less than the total of all previous payments made hereunder by Owner to Contractor.

7. The plans and specifications are intended to supplement each other, so that any works exhibited in either and not mentioned in the other are to be executed the same as if they were mentioned and set forth in both.

8. Should the Owner at any time during the process of the work request any modification, alterations or deviations in, additions to, or omissions from, this contract or the plans or specifications, he shall be at liberty to do so, and the shall in no way affect or make void this contract; but the amount thereof shall be added to or deducted from the amount of the contract price aforesaid, as the case may be, by a fair and reasonable valuation, based upon the actual cost of labor and materials plus 20 % profit to the Contractor. And this contract shall be held to be completed when the work is finished in accordance with the original plans as amended or modified by such changes, whatever may be the nature or extent thereof. The rule of practice to be observed in fulfillment of this paragraph shall be that upon the demand of either the owner or the Contractor, the character and valuation of any or all changes, omissions or extra work shall be agreed upon and fixed in writing, signed by the Owner and the Contractor, prior to execution. Where the alterations, deviations, additions or omissions from the said plans or specifications require the written approval of the Lien Holder, the Owner will secure said written approval. Provided however that the Contractor is not deemed to have waived his right to compensation for extra work if the same is not provided in writing.

9. Should Contractor, at any time during the progress of the work, refuse or neglect to supply sufficient material or workmen for the expeditious progress of said work, Owner may, upon giving three days' notice in writing to Contractor, by registered mail, (a copy of which shall be furnished to aforesaid Lien Holder), provided the necessary material and workmen to finish the said work and may enter upon the premises for such purpose and complete said work, the expense thereof shall be deducted from the said contract price, or if the total cost of the work to Owner exceeds the contract price, Contractor shall pay to owner upon demand the amount of such excess in addition to any and all other damages to which Owner may be entitled. In such event Owner may take possession of all materials and appliances belonging to Contractor upon or adjacent to the premises upon which said work is being performed and may use the same in the completion of said work.

10. The time during which the Contractor is delayed in said work by (a) the acts of Owner or his agents or employees or those claiming under agreement with or grant from Owner, or by (b) the Acts of God which Contractor could not have reasonably foreseen and provided against, or by (c) stormy or inclement weather which necessarily delays the work or by (d) any strikes, boycotts or like obstructive actions by employees or labor organizations and which are beyond the control of Contractor and which he cannot reasonably overcome, shall be added to the time for completion by a fair and reasonable allowance.

11. The Contractor shall not be responsible for any damage occasioned by the Owner or Owner's agent, Acts of God, earthquake or other causes beyond the control of Contractor, unless otherwise herein provided or unless he is obligated by the terms hereof to provide insurance against such hazard or hazards.

12. No payment hereunder nor occupancy of said improvements or any part thereof shall be construed as an acceptance of any work done up to the time of such payment or occupancy, except such items as are plainly evident to anyone not experienced in construction work, but the entire work is subject to inspection and approval of Owner at the time when it shall be claimed by Contractor that the work has been completed. At the completion of the work should there be any minor items in question, or to be adjusted, i.e., items not of a substantial nature, Owner may withhold from the payment then due a sum equal to twice the fairly estimated amount of money required to cover said items involved by such adjustments, and shall pay the difference to the Contractor. It is understood and agreed that the acceptance of any work done by the Owner shall not be construed to be an acceptance by aforesaid Lien Holder who is not a party hereto.

13. Owner agrees to sign and file for record within ten days after the completion and acceptance of said work a notice of completion (a copy thereof to be deposited with aforesaid Lien Holder at least forty-eight hours prior to such recording), and Contractor agrees upon receipt of final payment, to release the said work and property from any and all claims that may have accrued against same by reason of said construction. If the Contractor faithfully performs the obligations of this Contract on his part to be performed, he shall have the right to refuse to permit occupancy of the structure by the Owner or Owner's agent until Contractor has received the payment, if any, due hereunder at completion of construction, less such amounts as may be retained pursuant to mutual agreement of the Owner and Contractor under the provisions of the preceding paragraph hereof. Said Lien Holder has the right to make its own decision as to the completion of any work, independent of the parties hereto.

14. Contractor agrees to produce at its own expense and prior to the commencement of any work hereunder, Liability Insurance, with loss, if any, payable to any mortgagee or beneficiary, such insurance to be written to protect the Owner and the Contractor, as their interests may appear.

15. Contractor shall at his own expense carry workmen's compensation insurance and public liability insurance necessary for the full protection of Contractor and Owner during the progress of the work. Certificates of such insurance shall be filed with Owner and with said Lien Holder of Owner so requires, and shall be subject to the approval of both of them as to adequacy of protection.

16. Any controversy or claim arising out of or relating to this contract, or the breach thereof shall settle by arbitration in accordance with the Rules of the American Arbitration Association, and judgment upon the award rendered by the Arbitrator(s) may be entered in any Court having jurisdiction thereof.

17. Should either party hereto bring suit in court to enforce the terms hereof any judgment awarded shall include court costs and reasonable attorney's fees to the successful party.

18. Upon the completion of the work the Contractor agrees to remove all debris and surplus materials from Owner's said property (including under area of structure) and leave said property in a neat and broom clean condition.

19. The Contractor shall not assign or transfer this contract without first obtaining Owner's consent in writing.

20. The aforesaid Lien Holder is not party to this Contract and is not bound or obligated by or under any of the terms hereof.

21. Time is of the essence of this Contract as to both parties hereto.

Under the Mechanics' Lien Law (California Code of Civil Procedure, Section 1181 et seq.), any contractor, subcontractor, laborer, supplier or other person who helps to improve your property but is not paid for his work or supplies, has a right to enforce a claim against your property. This means that, after a court hearing, your property could be sold by a court officer and the proceeds of the sale used to satisfy the indebtedness. This can happen even if you have paid your own contractor in full, if the subcontractor, laborer, or supplier remains unpaid.

IN WITNESS WHEREOF, the said parties hereunto set their hands the day and year first above written.

LAMON CONSTRUCTION COMPANY, Inc.
881 MARKET STREET
YUBA CITY, CALIFORNIA 95991

By:

Cameron Park Community Services District
2502 Country Club Drive, Cameron Park, CA 95682

(owner)

By:

Lamon

CONSTRUCTION CO., INC.

Signatory to Carpenters, Operators, Laborers & Masons Union.

June 29, 2020

Steven A. Harms
Western Regional Manager
Fire Facilities, Inc.

RE: Cameron Park Fire Tower

Scope: Erect Wesco WS-3 per FFI parts list attached.

Excludes: Electrical/Power & connections, Concrete foundation, and bldg. pad/rough grade, Site Work.

A minimum of six weeks is required for erection.

See standard exclusions attached.

Price: 200,000 Erect Tower Only. Material by others.

Add alt #1. Provide foundation per attached preliminary drawing. Add 6 weeks for concrete scope. Price: \$ 68,000. Price subject to change upon final drawings.

Sincerely



Ken Norton, Vice President

**LAMON CONSTRUCTION CO., INC.
CONCRETE, ROUGH CARPENTRY, EARTHWORK &
UNDERGROUND UTILITIES**

STANDARD EXCLUSIONS

- Rock Excavation
- One move-in allowed
- Bid good for 30 days
- SWPPP plan
- Staking or surveying Unless Noted
- Locater by others Unless Noted
- Dirt grade to +/- .10 feet
- Topsoil or amended soil
- Water, meter & permits by GC
- Import or export except as noted
- Permits or fees
- Waiver of subrogation
- Contaminated soils
- Removal of old septic tanks/systems
- Connections at buildings by others
- Waterproofing
- Embeds of any kind (AB's, HD's, etc)
- Wet Soils (existing or from rain event)
- Excavation in lime treated soils
- Bldg Paper, Underlayment, Flashing, Weather proofing
- Welding
- Caulking, Fireproofing, Firecaulking,
- Penetrations for other trades
- Area drains, trench drain and associated piping not included
- Removal of lime treated soils in landscape areas
- Trash & Recycle Bins/Dumpsters. Lamon to clean up, GC to haul off.
- All recycle paperwork, reporting, weighing, etc...
- Temp Power – GC to provide temp power to slab capable of running multiple compressors and saws.
- Finish grade topsoil limited to onsite materials
- Quote limited to quantities noted
- Extra move-ins at \$3,500 each or as noted.
- Work to proceed within 60 days
- SWPPP installation or maintenance
- Landscape improvements
- Potholing by others
- No allowance is made for unsuitable soils
- Dump fees
- Dewatering
- Testing or inspections
- Bonds
- Legal fees
- Removal of old fuel tanks
- All systems stubbed to 5' of structure
- Non Wood Curbs for HVAC equipment
- Misc Metals/Sheet Metal
- Not responsible for protection of concrete after finishing operation is complete
- Finish Carpentry
- Raised Concrete @ Slab Sawcuts
- Welded Beam Hangers/Hardware by others
- Blocking not shown

NOTES

Proposal to be made apart of any agreement
Proposal contingent upon a mutually agreeable subcontract.
Proposal contingent upon a mutually agreeable schedule.
Any additional offhaul or import not noted will be at time and material rates
This bid is good for 30 days from the date of bid

PROPOSAL

FIRE FACILITIES INC.

314 WILBURN ROAD
SUN PRAIRIE, WI 53590-9401



"ASK BEFORE YOU BUY" - THE ONLY MAJOR STEEL FIRE TRAINING TOWER MANUFACTURED IN THE UNITED STATES



To: Erector/GC Cameron Park Fire tower Cameron Park, CA Proposal # 4401	From: Steven Harms Regional Manager 303-726-6013	Date: 5-18-20 Phone: 1-800-929-3726 or (608) 327-4100 Fax: 1-866-639-7012 or (608) 834-1843 E-mail: sharms@firefacilities.com
--	--	--

Remarks:

This proposal is regarding the price requested for Cameron Park, CA.
The total estimated weight for these materials is 58,602.09 lbs.
The total price for this fire tower or parts, F.O.B. destination is _____ as described below: * See tax note below
Freight:

Freight + Material Price: \$0.00

- Custom Painted Wesco Model WS-3 (Firefighter) with 1/2 Pitched and 1/2 Flat Roof
- Galv. Stairs And Railings Meet OSHA Standards For Private Use And Do Not Meet Building Code Requirements For Public Use
- 27' Tall Fire Escape With (2) Door(s) To the Flat Roof
- (4) Forged Swivel Rappelling Anchors (Rated for 10,000 lb Ultimate Load And 1,000 lb Working Load)
- (1) 3'-0" x 3'-0" Bilco Roof Hatch(es) With Straight Ladder to Flat Roof
- Parapet Wall On Flat Roof
- (1) Brass Siamese Fire Dept. Conn. (NST Thread) With Galv. 4" Dia. Riser (Approx. 22 ft. high)
- (1) Sprinkler system(s), 2-head
- (1) 11' x 18' Burn Room on 2nd Floor w/ (3) Doors
- (1) Three Rail Rappelling Railing System, 42" High, Prime Painted Tubes/Pipes
- (2) Burn Crib(s) - 12 Ga. Galv. Steel Class A Burn Prop (49" x 49" x 6" High)
- Slip-Resistant Roof Coating (Polyurethane Three-Coat Paint System) On All Roof Panels
- (1) Fire Watchman Temp. Meter(s): External Alarms, 16 Position
- Roof Railing Around Perimeter of Pitched Tower Roof

Per Drawings REVISED on March 6, 2020

Note: This fire training simulator shall be classified as a nonbuilding structure for structural design (i.e., seismic resisting system, load interpretation, etc.) and as an unoccupied structure for life/fire/safety. The price above reflects these stipulations and must be approved by the local plan reviewer before design work can begin.

Westec Burn Room Insulation System (The Industry's Best Includes A 15 Year Limited Warranty With Over 450 Installations Nationwide) This burn room insulation system exceeds all other systems and products that have been available to date. The system provides the highest insulation values on the market, it all but eliminates burn room maintenance by providing a durable, corrugated stainless steel protective face. It will withstand and provide continued protection at higher temperatures than any other product.

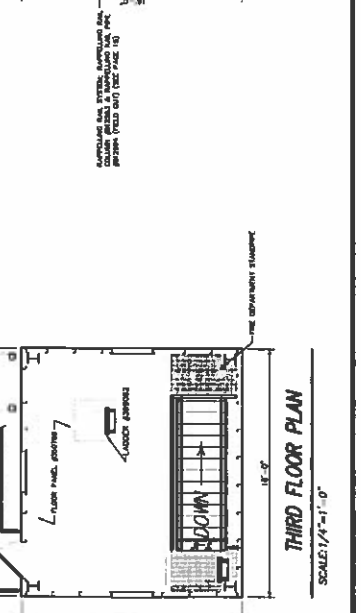
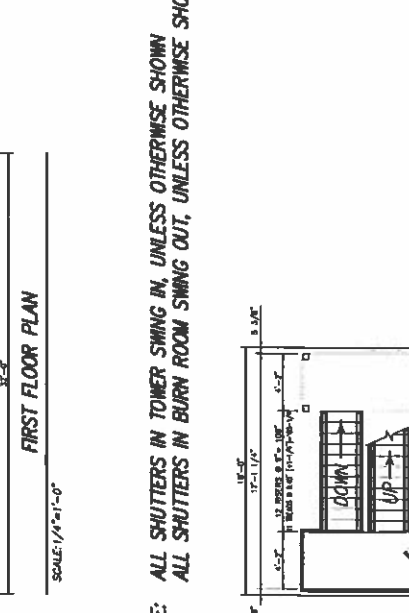
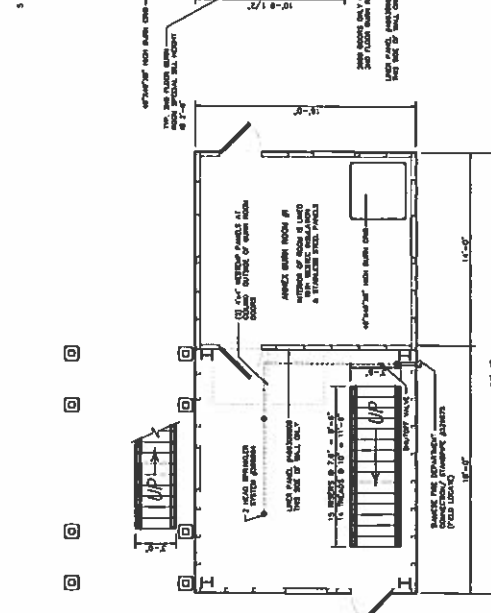
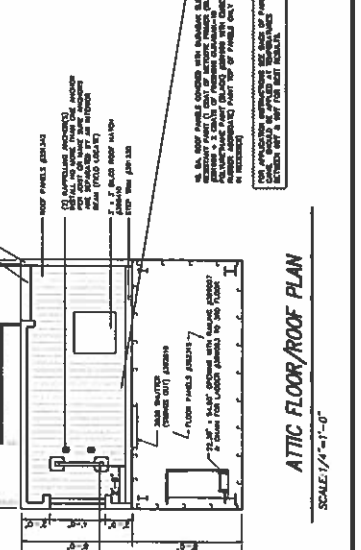
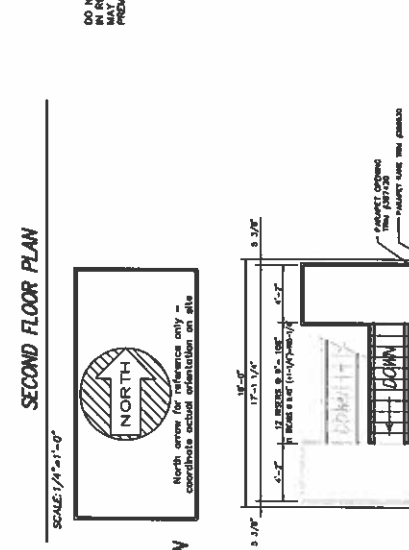
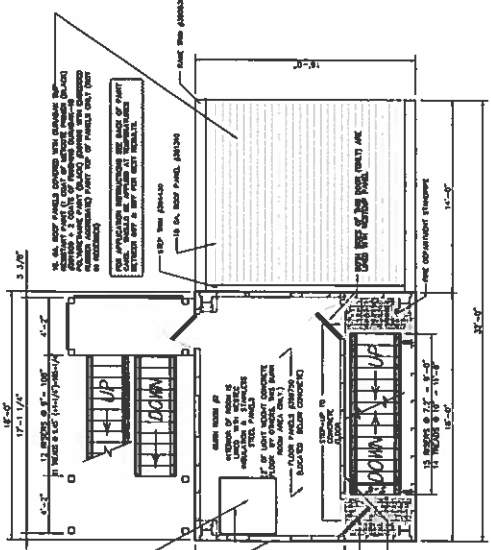
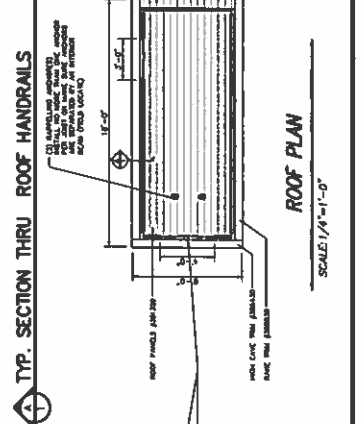
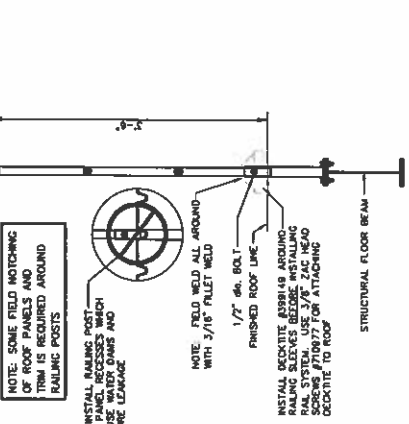
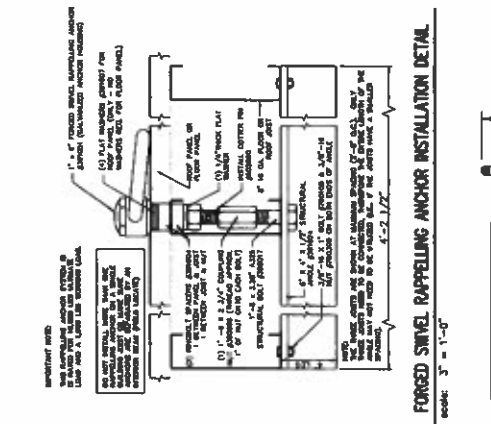

FIRE FACILITIES



STEEL FIRE TRAINING TOWERS
 315 WILSON ROAD, SAN FRANCISCO, CA 94133
 OFFICE: (415) 327-4100 FAX: (415) 624-1843
 TEL: (415) 327-4100 FAX: (415) 624-1843
 WWW.STEELFIRETRAININGTOWERS.COM

DATE: DECEMBER 5, 2011
 DRAWN BY: [Name]
 CHECKED BY: [Name]
 CUSTOMER: CAMERON PARK, CA
 WESCO MODEL: WS-3

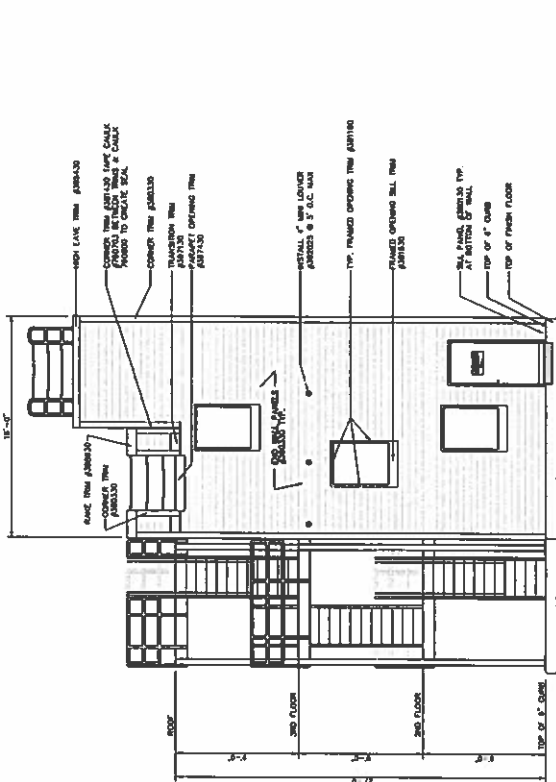

WEST END ELEVATION

SCALE: 1/4"=1'-0"

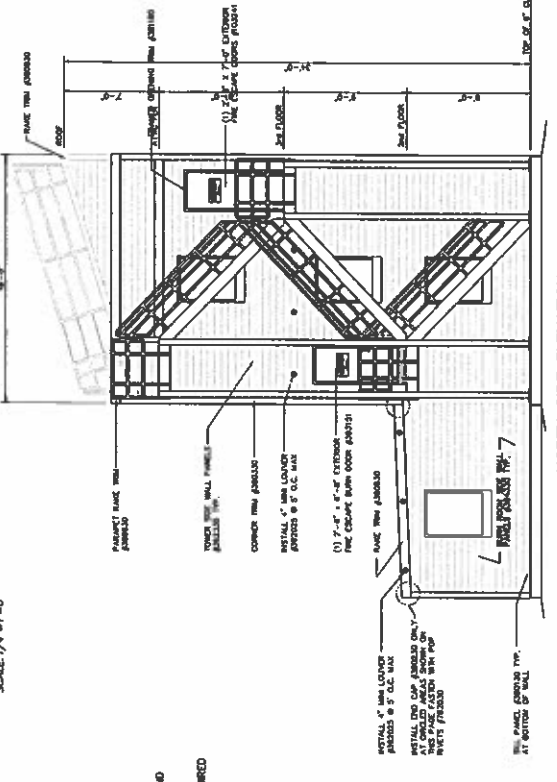

NORTH SIDE ELEVATION

SCALE: 1/4"=1'-0"

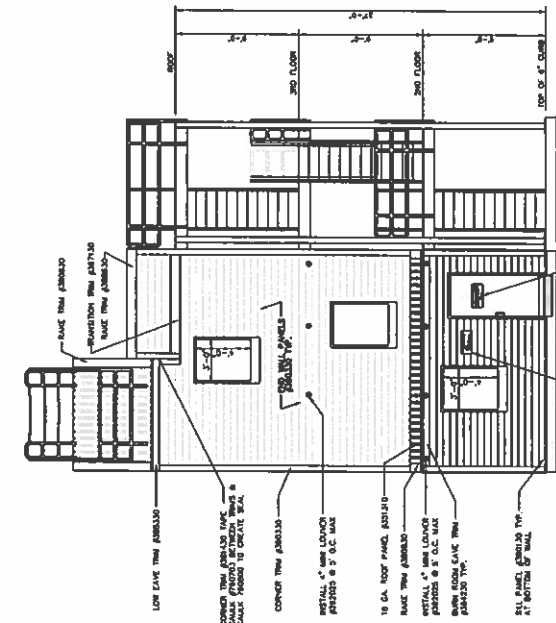

EAST END ELEVATION

SCALE: 1/4"=1'-0"

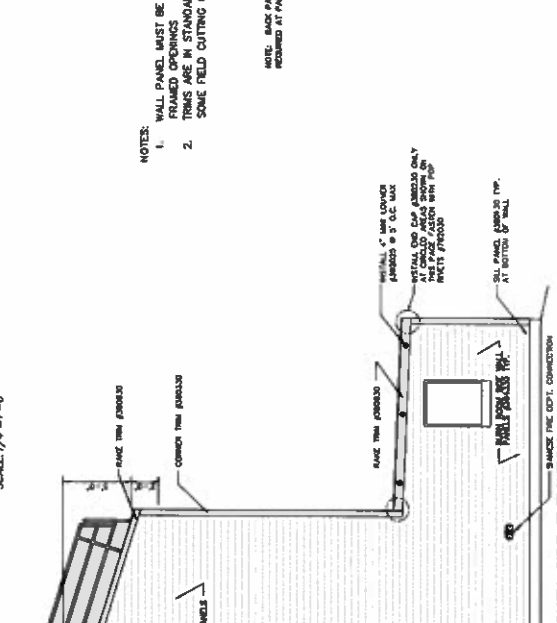

SOUTH SIDE ELEVATION

SCALE: 1/4"=1'-0"

- NOTES:
 1. WALL PANEL MUST BE FIELD CUT AROUND FRAMED OPENINGS
 2. FRAMES ARE IN STANDARDS 18" LENGTHS
 3. SOME FIELD CUTTING OF TRIMS IS REQUIRED

NOTE: 18" WIRE LOUVER PANELS REQUIRED AT PANEL SPICES

NOTE: 18" WIRE LOUVER PANELS @ 8" O.C. MAX AT CORNER AND SPICES ONLY THE PANEL ASSEMBLY WITH THE TRIM PARTITION

NOTE: 18" WIRE LOUVER PANELS @ 8" O.C. MAX AT BOTTOM OF WALL

NOTE: 18" WIRE LOUVER PANELS @ 8" O.C. MAX AT BOTTOM OF WALL

NO.	REVISION	DATE
1	ISSUED FOR PERMIT	11/15/11
2	REVISED PER COMMENTS	11/22/11
3		
4		

THIS DRAWING AND ALL PARTS HEREOF IS THE PROPERTY OF THE FACILITIES, INC.
 ANY REUSE, REPRODUCE, OR PART HEREOF WITHOUT PERMISSION IS PROHIBITED.

